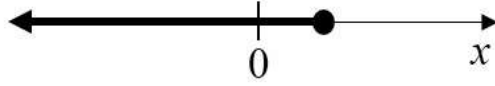
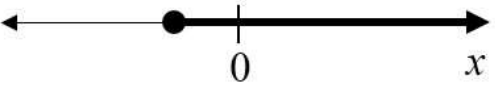
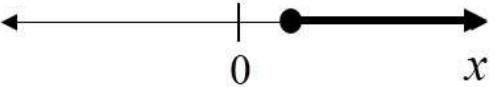
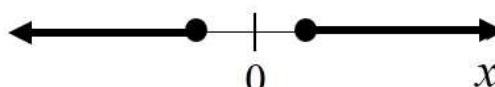

**GATE 2022 Aerospace Engineering (AE)**  
**GATE 2022 General Aptitude****Q.1 – Q.5 Carry ONE mark each.**

Q.1	Writing too many things on the _____ while teaching could make the students get _____.
(A)	bored / board
(B)	board / bored
(C)	board / board
(D)	bored / bored

**GATE 2022 Aerospace Engineering (AE)**

<p>Q.2</p>	<p>Which one of the following is a representation (not to scale and in bold) of all values of <math>x</math> satisfying the inequality <math>2 - 5x \leq -\frac{6x-5}{3}</math> on the real number line?</p>
<p>(A)</p>	
<p>(B)</p>	
<p>(C)</p>	
<p>(D)</p>	

**GATE 2022 Aerospace Engineering (AE)**

Q.3	If $f(x) = 2 \ln(\sqrt{e^x})$ , what is the area bounded by $f(x)$ for the interval $[0, 2]$ on the $x$ -axis?
(A)	$\frac{1}{2}$
(B)	1
(C)	2
(D)	4

**GATE 2022 Aerospace Engineering (AE)**

Q.4	<p>A person was born on the fifth Monday of February in a particular year.</p> <p>Which one of the following statements is correct based on the above information?</p>
(A)	The 2 <sup>nd</sup> February of that year is a Tuesday
(B)	There will be five Sundays in the month of February in that year
(C)	The 1 <sup>st</sup> February of that year is a Sunday
(D)	All Mondays of February in that year have even dates

**GATE 2022 Aerospace Engineering (AE)**

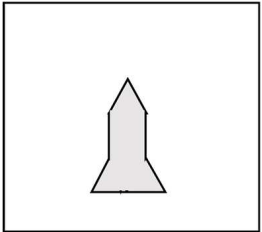
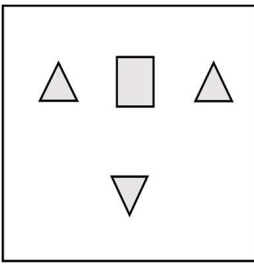
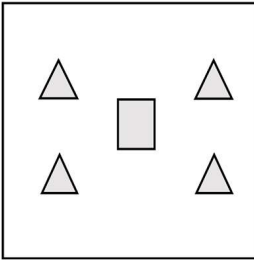
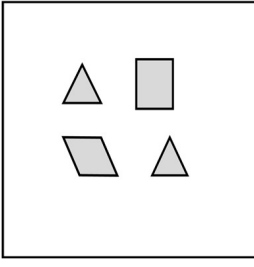
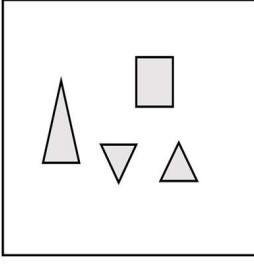
<p>Q.5</p>	<div style="text-align: center;">  </div> <p>Which one of the groups given below can be assembled to get the shape that is shown above using each piece only once without overlapping with each other? (rotation and translation operations may be used).</p>
<p>(A)</p>	<div style="text-align: center;">  </div>
<p>(B)</p>	<div style="text-align: center;">  </div>
<p>(C)</p>	<div style="text-align: center;">  </div>
<p>(D)</p>	<div style="text-align: center;">  </div>

**GATE 2022 Aerospace Engineering (AE)****Q. 6 – Q. 10 Carry TWO marks each.**

Q.6	<p>Fish belonging to species S in the deep sea have skins that are extremely black (ultra-black skin). This helps them not only to avoid predators but also sneakily attack their prey. However, having this extra layer of black pigment results in lower collagen on their skin, making their skin more fragile.</p> <p>Which one of the following is the CORRECT logical inference based on the information in the above passage?</p>
(A)	Having ultra-black skin is only advantageous to species S
(B)	Species S with lower collagen in their skin are at an advantage because it helps them avoid predators
(C)	Having ultra-black skin has both advantages and disadvantages to species S
(D)	Having ultra-black skin is only disadvantageous to species S but advantageous only to their predators

**GATE 2022 Aerospace Engineering (AE)**

Q.7	<p>For the past <math>m</math> days, the average daily production at a company was 100 units per day.</p> <p>If today's production of 180 units changes the average to 110 units per day, what is the value of <math>m</math>?</p>
(A)	18
(B)	10
(C)	7
(D)	5

**GATE 2022 Aerospace Engineering (AE)**

<p>Q.8</p>	<p>Consider the following functions for non-zero positive integers, <math>p</math> and <math>q</math>.</p> $f(p, q) = \underbrace{p \times p \times p \times \dots \times p}_{q \text{ terms}} = p^q; \quad f(p, 1) = p$ $g(p, q) = p^{p^{p^{p^{\dots}}}} \text{ (up to } q \text{ terms)}; \quad g(p, 1) = p$ <p>Which one of the following options is correct based on the above?</p>
<p>(A)</p>	<p><math>f(2,2) = g(2,2)</math></p>
<p>(B)</p>	<p><math>f(g(2,2), 2) &lt; f(2, g(2,2))</math></p>
<p>(C)</p>	<p><math>g(2,1) \neq f(2,1)</math></p>
<p>(D)</p>	<p><math>f(3,2) &gt; g(3,2)</math></p>



**GATE 2022 Aerospace Engineering (AE)**

Q.9

Four cities P, Q, R and S are connected through one-way routes as shown in the figure. The travel time between any two connected cities is one hour. The boxes beside each city name describe the starting time of first train of the day and their frequency of operation. For example, from city P, the first trains of the day start at 8 AM with a frequency of 90 minutes to each of R and S. A person does not spend additional time at any city other than the waiting time for the next connecting train.

If the person starts from R at 7 AM and is required to visit S and return to R, what is the minimum time required?

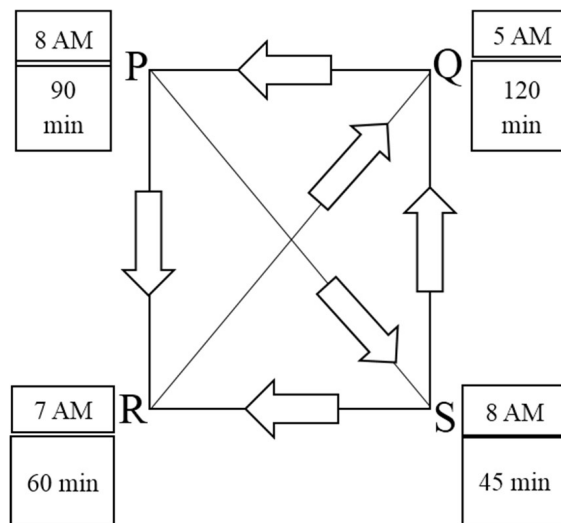

(A) 6 hours 30 minutes

(B) 3 hours 45 minutes

(C) 4 hours 30 minutes

(D) 5 hours 15 minutes

**GATE 2022 Aerospace Engineering (AE)**

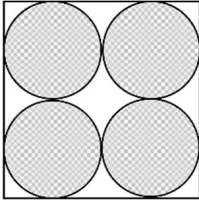
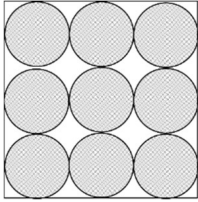
<p>Q.10</p>	<p>Equal sized circular regions are shaded in a square sheet of paper of 1 cm side length. Two cases, case M and case N, are considered as shown in the figures below. In the case M, four circles are shaded in the square sheet and in the case N, nine circles are shaded in the square sheet as shown.</p> <p>What is the ratio of the areas of unshaded regions of case M to that of case N?</p> <div style="display: flex; justify-content: space-around; align-items: center;"> <div style="text-align: center;">  <p>case M</p> </div> <div style="text-align: center;">  <p>case N</p> </div> </div>
<p>(A)</p>	<p>2 : 3</p>
<p>(B)</p>	<p>1 : 1</p>
<p>(C)</p>	<p>3 : 2</p>
<p>(D)</p>	<p>2 : 1</p>

**GATE 2022 Aerospace Engineering (AE)**

**Q.11 – Q.35 Carry ONE mark Each**

Q.11	The equation of the straight line representing the tangent to the curve $y = x^2$ at the point (1,1) is
(A)	$y = 2x - 2$
(B)	$x = 2y - 1$
(C)	$y - 1 = 2(x - 1)$
(D)	$x - 1 = 2(y - 1)$

Q.12	Let $\hat{i}$ , $\hat{j}$ , and $\hat{k}$ be the unit vectors in the x, y and z directions, respectively. If the vector $\hat{i} + \hat{j}$ is rotated about positive $\hat{k}$ by $135^\circ$ , one gets
(A)	$-\hat{i}$
(B)	$-\hat{j}$
(C)	$-\frac{1}{\sqrt{2}}\hat{j}$
(D)	$-\sqrt{2}\hat{i}$

**GATE 2022 Aerospace Engineering (AE)**

Q.13	Let $x$ be a real number and $i = \sqrt{-1}$ . Then the real part of $\cos(ix)$ is
(A)	$\sinh x$
(B)	$\cosh x$
(C)	$\cos x$
(D)	$\sin x$

Q.14	The point of maximum entropy on a Fanno-curve in a Temperature-Entropy (T-s) diagram represents the
(A)	maximum flow Mach number
(B)	minimum flow Mach number
(C)	sonic Mach number
(D)	normal shock in the flow

**GATE 2022 Aerospace Engineering (AE)**

Q.15	Consider a two-dimensional potential flow over a cylinder. If the freestream speed is $U_\infty$ , the maximum speed on the cylinder surface is
(A)	$\frac{U_\infty}{2}$
(B)	$\frac{3U_\infty}{2}$
(C)	$2U_\infty$
(D)	$\frac{4U_\infty}{3}$

**GATE 2022 Aerospace Engineering (AE)**

Q.16

Consider steady, two-dimensional, incompressible flow over a non-porous flat plate as shown in the figure. For the control volume PQRS, the speed,  $u_\infty$ , at section PQ is uniform and the speed at section RS is given by  $u(y) = A_0 \left(\frac{y}{h}\right)^n$ , where  $n$  is a positive integer. The value of  $A_0$  for which the flow through section PS *will vanish* is:

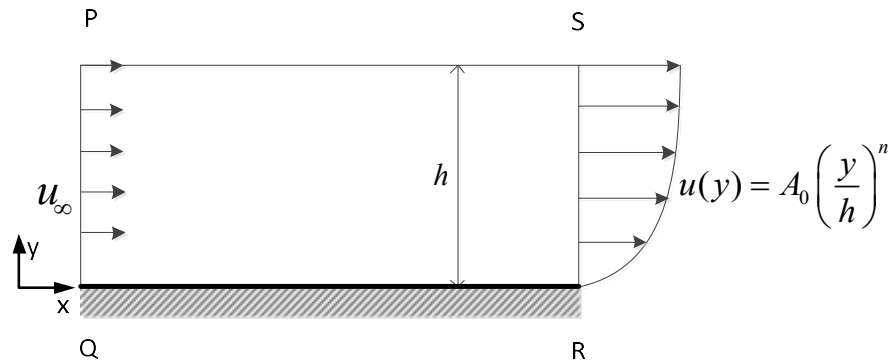

(A)  $\frac{u_\infty}{n + 1}$

(B)  $u_\infty(n + 1)$

(C)  $\frac{u_\infty}{n - 1}$

(D)  $u_\infty(n - 1)$

**GATE 2022 Aerospace Engineering (AE)**

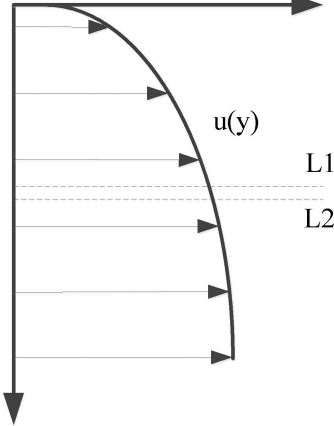
<p>Q.17</p>	<p>Consider the velocity distribution, <math>u(y)</math> shown in the figure. For two adjacent fluid layers L1 and L2, the viscous force exerted by L1 on L2 is</p> 
<p>(A)</p>	<p>to the right</p>
<p>(B)</p>	<p>to the left</p>
<p>(C)</p>	<p>vertically upwards</p>
<p>(D)</p>	<p>vertically downwards</p>

**GATE 2022 Aerospace Engineering (AE)**

Q.18	The service ceiling of an airplane is the altitude
(A)	at which maximum rate of climb is 100 m/min
(B)	beyond which theoretically the airplane cannot sustain level flight
(C)	at which maximum power is required for flight
(D)	at which maximum rate of climb is 100 ft/min

Q.19	Regarding the horizontal tail of a conventional airplane, which one of the following statements is true?
(A)	It contributes to $C_{m_\alpha} < 0$
(B)	It makes $C_{m_\alpha} = 0$
(C)	It makes $C_{m_\alpha} > 0$
(D)	It makes $C_{m_0} > 0$ and $C_{m_\alpha} > 0$



**GATE 2022 Aerospace Engineering (AE)**

<p>Q.20</p>	<p>A beam with a symmetrical T-shaped cross-section, as shown in the figure, is subjected to pure bending. The maximum magnitude of the normal stress is realised:</p> <div style="text-align: center;">  </div>
<p>(A)</p>	<p>only at the top fibres of the cross-section</p>
<p>(B)</p>	<p>only at the bottom fibres of the cross-section</p>
<p>(C)</p>	<p>both at the top and bottom fibres of the cross-section</p>
<p>(D)</p>	<p>only at the centroidal fibres of the cross-section</p>

**GATE 2022 Aerospace Engineering (AE)**

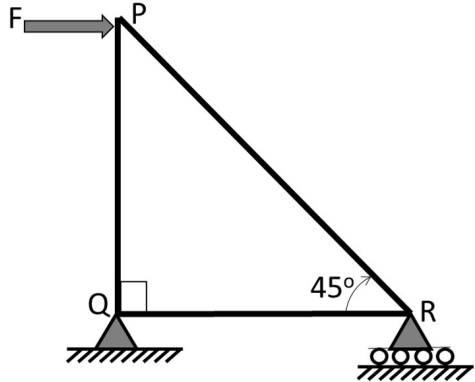
<p>Q.21</p>	<p>A three-member truss is simply supported at Q and R, and loaded at P by a horizontal force <math>F</math> as shown. The force in QR is</p> 
<p>(A)</p>	<p>0</p>
<p>(B)</p>	<p><math>F</math> (tensile)</p>
<p>(C)</p>	<p><math>\frac{F}{\sqrt{2}}</math> (compressive)</p>
<p>(D)</p>	<p><math>\sqrt{2}F</math> (tensile)</p>

**GATE 2022 Aerospace Engineering (AE)**

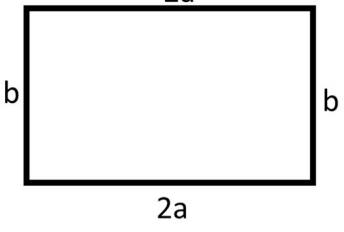
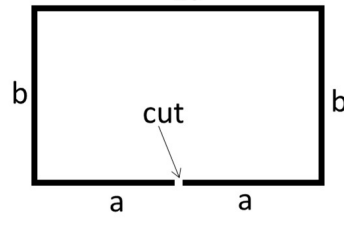
<p>Q.22</p>	<p>The closed <i>thin-walled</i> rectangular channel shown in figure (i) is opened by introducing a sharp cut at the center of the bottom edge, as shown in figure (ii). Which one of the following statements is correct?</p> <div style="display: flex; justify-content: space-around; align-items: center;"> <div style="text-align: center;"> <p>(i)</p>  </div> <div style="text-align: center;"> <p>(ii)</p>  </div> </div>
<p>(A)</p>	<p>Centroids of (i) and (ii) coincide while shear centers do not</p>
<p>(B)</p>	<p>Shear centers of (i) and (ii) coincide while centroids do not</p>
<p>(C)</p>	<p>Both centroids and shear centers of (i) and (ii) coincide</p>
<p>(D)</p>	<p>Neither centroids nor shear centers of (i) and (ii) coincide</p>

<p>Q.23</p>	<p>The region of <i>highest static temperature</i> in a rocket engine and the region of <i>highest heat flux</i> are _____, respectively.</p>
<p>(A)</p>	<p>nozzle throat and nozzle entry</p>
<p>(B)</p>	<p>combustion chamber and nozzle throat</p>
<p>(C)</p>	<p>nozzle exit and nozzle throat</p>
<p>(D)</p>	<p>nozzle throat and combustion chamber</p>

**GATE 2022 Aerospace Engineering (AE)**

Q.24	If $\hat{a}, \hat{b}, \hat{c}$ are three mutually perpendicular unit vectors, then $\hat{a} \cdot (\hat{b} \times \hat{c})$ can take the value(s)
(A)	0
(B)	1
(C)	-1
(D)	$\infty$

Q.25	Across an oblique shock wave in a calorifically perfect gas,
(A)	the stagnation enthalpy changes
(B)	the stagnation entropy changes
(C)	the stagnation temperature changes
(D)	the speed of sound changes

**GATE 2022 Aerospace Engineering (AE)**

Q.26	NACA 2412 airfoil has
(A)	4% maximum camber with respect to chord
(B)	maximum camber at 40% chord
(C)	12% maximum thickness to chord ratio
(D)	maximum camber at 20% chord

Q.27	For International Standard Atmosphere (ISA) up to 11 km, which of the following statement(s) is/are true?
(A)	The hydrostatic/ aerostatic equation is used
(B)	The temperature lapse rate is taken as $-10^{-2} K/m$
(C)	The sea level conditions are taken as: pressure, $p_s = 1.01325 \times 10^5 Pa$ ; temperature, $T_s = 300 K$ ; density, $\rho_s = 1.225 kg/m^3$
(D)	Air is treated as a perfect gas

**GATE 2022 Aerospace Engineering (AE)**

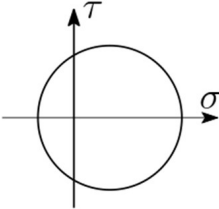
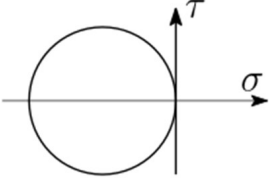
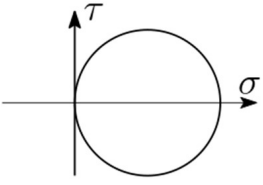
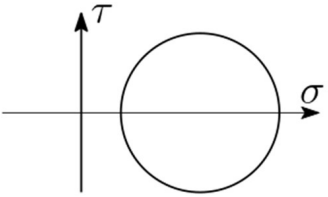
Q.28	<p>Let <math>\sigma</math> and <math>\tau</math> represent the normal stress and shear stress on a plane, respectively. The Mohr circle(s) that may possibly represent the state of stress at points in a beam of rectangular cross-section under <b><i>pure bending</i></b> is/are:</p>
(A)	
(B)	
(C)	
(D)	

**GATE 2022 Aerospace Engineering (AE)**

Q.29	An isotropic linear elastic material point under plane strain condition in the x-y plane always obeys:
(A)	out-of-plane normal strain, $\epsilon_{zz} = 0$
(B)	out-of-plane normal stress, $\sigma_{zz} = 0$
(C)	out-of-plane shear stress, $\tau_{xz} = 0$
(D)	out-of-plane shear strain, $\gamma_{xz} = 0$

Q.30	A high-pressure-ratio multistage axial compressor encounters an extreme loading mismatch during starting. Which of the following technique(s) can be used to alleviate this problem?
(A)	Blade cooling
(B)	Variable angle stator vanes
(C)	Blow-off valves
(D)	Multi-spool shaft

**GATE 2022 Aerospace Engineering (AE)**

Q.31	The arc length of the parametric curve: $x = \cos \theta$ , $y = \sin \theta$ , $z = \theta$ from $\theta = 0$ to $\theta = 2\pi$ is equal to _____ (round off to one decimal place).

Q.32	An unpowered glider is flying at a glide angle of 10 degrees. Its lift-to-drag ratio is _____ (round off to two decimal places).

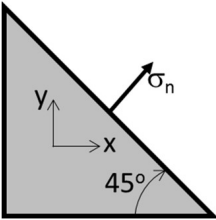
Q.33	<p>The two-dimensional plane-stress state at a point is:</p> $\sigma_{xx} = 110 \text{ MPa}; \sigma_{yy} = 30 \text{ MPa}; \tau_{xy} = 40 \text{ MPa}.$ <p>The normal stress, <math>\sigma_n</math>, on a plane inclined <math>45^\circ</math> as shown in the figure is ____ MPa (round off to the nearest integer).</p> 



**GATE 2022 Aerospace Engineering (AE)**

Q.34	<p>In a <i>static</i> test, a turbofan engine with <i>bypass ratio</i> of 9 has core hot exhaust speed 1.5 times that of fan exhaust speed. The engine is operated at a fuel to air ratio of <math>f = 0.03</math>. Both the fan and the core streams have no pressure thrust. The ratio of fan thrust to thrust from the core engine is _____ (round off to one decimal place).</p>

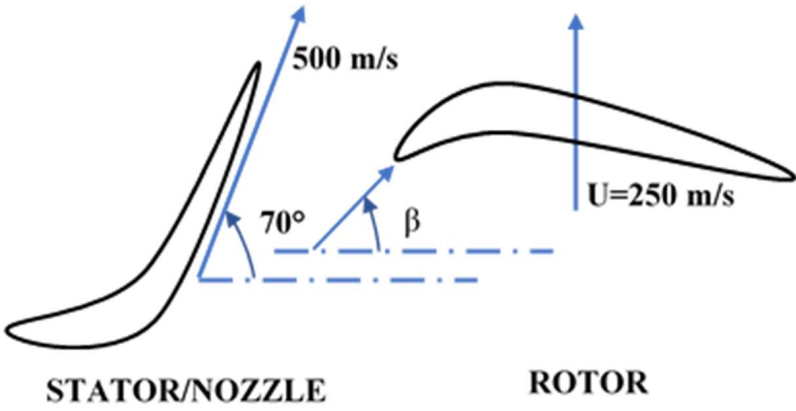
Q.35	<p>In a single stage turbine, the hot gases come out of stator/ nozzle at a speed of 500 m/s and at an angle of 70 degrees with the turbine axis as shown. The design speed of the rotor blade is 250 m/s at the mean blade radius. The rotor blade angle, <math>\beta</math>, at the leading edge is _____ degrees (round off to one decimal place).</p>  <p style="text-align: center;">STATOR/NOZZLE                      ROTOR</p>

**GATE 2022 Aerospace Engineering (AE)**

**Q.36 – Q.65 Carry TWO marks Each**

Q.36	The height of a right circular cone of maximum volume that can be enclosed within a hollow sphere of radius $R$ is
(A)	$R$
(B)	$\frac{5}{4}R$
(C)	$\frac{4}{3}R$
(D)	$\frac{3}{2}R$

Q.37	Consider the differential equation $\frac{d^2y}{dx^2} - 2\frac{dy}{dx} + y = 0$ .  The boundary conditions are $y = 0$ and $\frac{dy}{dx} = 1$ at $x = 0$ .  Then the value of $y$ at $x = 1/2$ is
(A)	0
(B)	$\sqrt{e}$
(C)	$\frac{\sqrt{e}}{2}$
(D)	$\sqrt{\frac{e}{2}}$

**GATE 2022 Aerospace Engineering (AE)**

Q.38	<p>Consider the partial differential equation <math>\frac{\partial^2 f}{\partial x^2} + \frac{\partial^2 f}{\partial y^2} = 0</math> where <math>x, y</math> are real.</p> <p>If <math>f(x, y) = a(x)b(y)</math>, where <math>a(x)</math> and <math>b(y)</math> are real functions, which one of the following statements can be true?</p>
(A)	$a(x)$ is a periodic function and $b(y)$ is a linear function
(B)	both $a(x)$ and $b(y)$ are exponential functions
(C)	$a(x)$ is a periodic function and $b(y)$ is an exponential function
(D)	both $a(x)$ and $b(y)$ are periodic functions

Q.39	<p>A cylindrical object of diameter 900 mm is designed to move <i>axially</i> in air at 60 m/s. Its drag is estimated on a geometrically half-scaled model in water, assuming flow similarity.</p> <p>Coefficients of dynamic viscosity and densities for air and water are <math>1.86 \times 10^{-5}</math> Pa-s, <math>1.2 \text{ kg/m}^3</math> and <math>1.01 \times 10^{-3}</math> Pa-s, <math>1000 \text{ kg/m}^3</math> respectively.</p> <p>Drag measured for the model is 2280 N. Drag experienced by the full-scale object is ____ N (rounded off to the nearest integer).</p>
(A)	322
(B)	644
(C)	1288
(D)	2576

**GATE 2022 Aerospace Engineering (AE)**

Q.40	Consider a conventional subsonic fixed-wing airplane. $e$ is the Oswald efficiency factor and $AR$ is the aspect ratio. Corresponding to the minimum $\left(\frac{C_D}{C_L^{3/2}}\right)$ , which of the following relations is true?
(A)	$\frac{C_D}{C_L^2} = \frac{1}{\pi e AR}$
(B)	$\frac{C_D}{C_L^2} = \frac{4}{3\pi e AR}$
(C)	$\frac{C_D}{C_L} = \frac{1}{\pi e AR}$
(D)	$\frac{C_D}{\sqrt{C_L}} = \frac{1}{\sqrt{\pi e AR}}$

**GATE 2022 Aerospace Engineering (AE)**

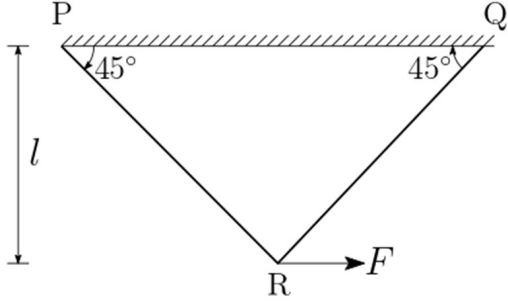
<p>Q.41</p>	<p>A horizontal load <math>F</math> is applied at point R on a two-member truss, as shown in the figure. Both the members are prismatic with cross-sectional area, <math>A_0</math>, and made of the same material with Young's modulus <math>E</math>.</p> <p>The horizontal displacement of point R is:</p> 
<p>(A)</p>	<p>0</p>
<p>(B)</p>	<p><math>\frac{Fl}{EA_0}</math></p>
<p>(C)</p>	<p><math>\sqrt{2} \frac{Fl}{EA_0}</math></p>
<p>(D)</p>	<p><math>2 \frac{Fl}{EA_0}</math></p>

**GATE 2022 Aerospace Engineering (AE)**

Q.42	Which of the following is <b>NOT</b> always true for a combustion process taking place in a closed system?
(A)	Total number of atoms is conserved
(B)	Total number of molecules is conserved
(C)	Total number of atoms of each element is conserved
(D)	Total mass is conserved

Q.43	The real function $y = \sin^2( x )$ is
(A)	continuous for all $x$
(B)	differentiable for all $x$
(C)	not continuous at $x = 0$
(D)	not differentiable at $x = 0$

**GATE 2022 Aerospace Engineering (AE)**

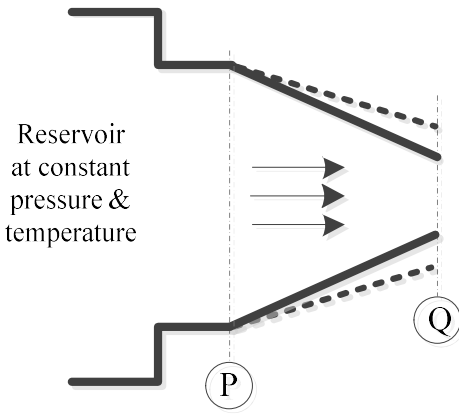
<p>Q.44</p>	<p>A convergent nozzle fed from a constant pressure, constant temperature reservoir, is discharging air to atmosphere at 1 bar (absolute) with choked flow at the exit (marked as <math>Q</math>).</p> <p>Flow through the nozzle can be assumed to be isentropic.</p> <p>If the exit area of the nozzle is increased while all the reservoir parameters and ambient conditions remain the same, then at steady state</p> 
<p>(A)</p>	<p>the nozzle will remain choked</p>
<p>(B)</p>	<p>the nozzle will be un-choked</p>
<p>(C)</p>	<p>the Mach number at section P will increase</p>
<p>(D)</p>	<p>the Mach number at section P will decrease</p>

**GATE 2022 Aerospace Engineering (AE)**

Q.45	For a conventional airplane in straight, level, constant velocity flight condition, which of the following condition(s) is/are possible on Euler angles ( $\phi, \theta, \psi$ ), angle of attack ( $\alpha$ ) and the sideslip angle ( $\beta$ )?
(A)	$\phi = 0^\circ, \theta = 2^\circ, \psi = 0^\circ, \alpha = 2^\circ, \beta = 0^\circ$
(B)	$\phi = 5^\circ, \theta = 0^\circ, \psi = 0^\circ, \alpha = 2^\circ, \beta = 0^\circ$
(C)	$\phi = 0^\circ, \theta = 3^\circ, \psi = 0^\circ, \alpha = 3^\circ, \beta = 5^\circ$
(D)	$\phi = 0^\circ, \theta = 5^\circ, \psi = 0^\circ, \alpha = 2^\circ, \beta = 5^\circ$

Q.46	<p>Consider a high Earth-orbiting satellite of angular momentum per unit mass <math>\vec{h}</math> and eccentricity <math>e</math>.</p> <p>The mass of the Earth is <math>M</math> and <math>G</math> is the universal gravitational constant.</p> <p>The distance between the satellite's center of mass and the Earth's center of mass is <math>r</math>, the true anomaly is <math>\theta</math>, and the phase angle is zero.</p> <p>Which of the following statements is/are true?</p>
(A)	The trajectory equation is $r = r(\theta) = \frac{ \vec{h} }{GM(1+e \cos \theta)}$
(B)	The trajectory equation is $r = r(\theta) = \frac{ \vec{h} ^2}{GM(1+e \cos \theta)}$
(C)	$\vec{h}$ is conserved
(D)	The sum of potential energy and kinetic energy of the satellite is conserved





**GATE 2022 Aerospace Engineering (AE)**

<p>Q.47</p>	<p>A rocket operates at an absolute chamber pressure of 20 bar to produce thrust, <math>F_1</math>.</p> <p>The hot exhaust is optimally expanded to 1 bar (absolute pressure) using a convergent-divergent nozzle with exit to throat area ratio <math>\left(\frac{A_e}{A_t}\right)</math> of 3.5 and thrust coefficient, <math>C_{F,1} = 1.42</math>.</p> <p>The same rocket when operated at an absolute chamber pressure of 50 bar produces thrust <math>F_2</math> and the thrust coefficient is <math>C_{F,2}</math>.</p> <p>Which of the following statement(s) is/are correct?</p>
<p>(A)</p>	$\frac{F_2}{F_1} = 2.5$
<p>(B)</p>	$\frac{F_2}{F_1} > 2.5$
<p>(C)</p>	$\frac{C_{F,2}}{C_{F,1}} = 1$
<p>(D)</p>	$\frac{C_{F,2}}{C_{F,1}} > 1$

<p>Q.48</p>	<p><math>\vec{v} = x^3\hat{i} + y^3\hat{j} + z^3\hat{k}</math> is a vector field where <math>\hat{i}, \hat{j}, \hat{k}</math> are the base vectors of a cartesian coordinate system.</p> <p>Using the Gauss divergence theorem, the value of the outward flux of the vector field over the surface of a sphere of unit radius centered at the origin is _____ (rounded off to one decimal place).</p>
-------------	---

**GATE 2022 Aerospace Engineering (AE)**

Q.49	<p>The largest eigenvalue of the given matrix is _____.</p> $\begin{bmatrix} 0 & 1 & 1 \\ 1 & 0 & 1 \\ 1 & 1 & 0 \end{bmatrix}$

Q.50	<p>A rotational velocity field in an air flow is given as <math>\vec{V} = ay\hat{i} + bx\hat{j}</math>, with <math>a = 10 \text{ s}^{-1}</math>, <math>b = 20 \text{ s}^{-1}</math>.</p> <p>The air density is <math>1.0 \text{ kg/m}^3</math> and the pressure at <math>(x, y) = (0 \text{ m}, 0 \text{ m})</math> is <math>100 \text{ kPa}</math>.</p> <p>Neglecting gravity, the pressure at <math>(x, y) = (6 \text{ m}, 8 \text{ m})</math> is _____ <math>\text{kPa}</math> (rounded off to nearest integer).</p>

Q.51	<p>Consider a circulation distribution over a finite wing given by the equation below.</p> $\Gamma(y) = \begin{cases} \Gamma_0 \left(1 - \frac{2y}{b}\right) & \text{if } 0 \leq y \leq \frac{b}{2} \\ \Gamma_0 \left(1 + \frac{2y}{b}\right) & \text{if } -\frac{b}{2} \leq y \leq 0 \end{cases}$ <p>The wingspan <math>b</math> is <math>10 \text{ m}</math>, the maximum circulation <math>\Gamma_0</math> is <math>20 \text{ m}^2/\text{s}</math>, density of air is <math>1.2 \text{ kg/m}^3</math> and the free stream speed is <math>80 \text{ m/s}</math>.</p> <p>The lift over the wing is _____ <math>\text{N}</math> (rounded off to the nearest integer).</p>

## GATE 2022 Aerospace Engineering (AE)

Q.52

Consider a solid cylinder housed inside another cylinder as shown in the figure. Radius of the inner cylinder is 1 m and its height is 2 m. The gap between the cylinders is 5 mm and is filled with a fluid of viscosity  $10^{-4}$  Pa-s.

The inner cylinder is rotating at a constant angular speed of 5 rad/s while the outer cylinder is stationary. Friction at the bottom surfaces can be ignored. Velocity profile in the vertical gap between the cylinders can be assumed to be linear.

The driving moment required for the rotating motion of the inner cylinder is \_\_\_\_\_ Nm (rounded off to two decimal places).

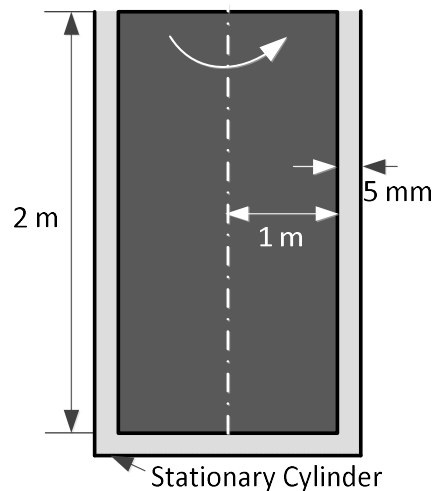

**GATE 2022 Aerospace Engineering (AE)**

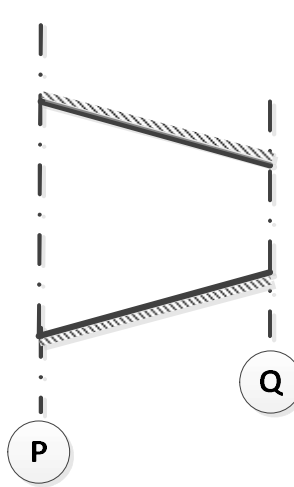
<p>Q.53</p>	<p>In a converging duct, area and velocity at section P are <math>1 \text{ m}^2</math> and <math>15 \text{ m/s}</math>, respectively. The temperature of the fluid is <math>300 \text{ K}</math>.</p> <p>Air flow through the nozzle can be assumed to be inviscid and isothermal. Characteristic gas constant is <math>287 \text{ J/(kg-K)}</math> and ratio of specific heats is <math>1.4</math> for air.</p> <p>To ensure that the air flow remains incompressible (Mach number, <math>M \leq 0.3</math>) in the duct, the minimum area required at section Q is _____ <math>\text{m}^2</math> (rounded off to two decimal places).</p> <div style="text-align: center; margin-top: 20px;">  </div>
-------------	--

<p>Q.54</p>	<p>Consider a thin symmetric airfoil at <math>2^\circ</math> angle of attack in a uniform flow at <math>50 \text{ m/s}</math>. The pitching moment coefficient about its leading edge is _____ (rounded off to three decimal places).</p>

**GATE 2022 Aerospace Engineering (AE)**

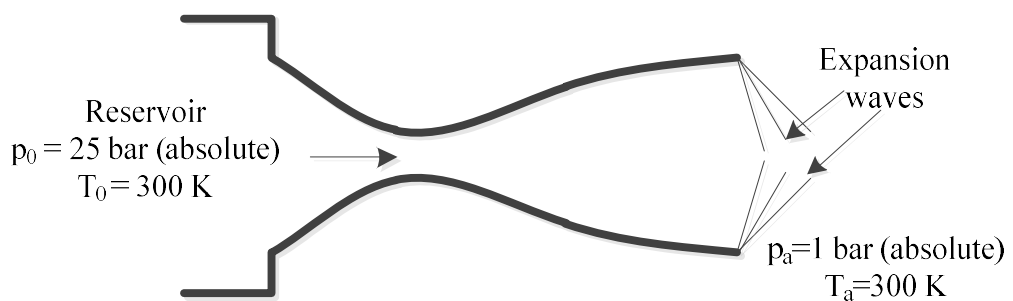
<p>Q.55</p>	<p>A convergent-divergent nozzle with adiabatic walls is designed for an exit Mach number of 2.3. It is discharging air to atmosphere under the conditions indicated in the figure.</p> <p>Flow through the nozzle is inviscid, the characteristic gas constant for air is 287 J/(kg-K), and <math>\gamma = 1.4</math>.</p> <p>When the reservoir pressure is 25 bar (absolute), and temperature is 300 K, Prandtl-Meyer expansion waves appear at the nozzle exit as shown.</p> <p>The minimum percentage change in the reservoir pressure required to eliminate the wave system at the nozzle exit under steady state is _____%.</p> <div style="text-align: center; margin-top: 20px;">  </div>

<p>Q.56</p>	<p>A conventional airplane of mass 5000 kg is doing a level turn of radius 1000 m at a constant speed of 100 m/s at sea level.</p> <p>Taking the acceleration due to gravity as 10 m/s<sup>2</sup>, the bank angle of the airplane is _____ degrees.</p>

**GATE 2022 Aerospace Engineering (AE)**

Q.57

Given: The tip deflection and tip slope for a tip loaded cantilever of length  $L$  are:  $\frac{NL^3}{3EI}$  and  $\frac{NL^2}{2EI}$ , respectively, where  $N$  is the tip force and  $EI$  is the flexural rigidity.

A cantilever  $PQ$  of rectangular cross-section is subjected to transverse load,  $F$ , at its mid-point. Two cases are considered as shown in the figure. In Case I, the end  $Q$  is free and in Case II,  $Q$  is simply supported.

The ratio of the magnitude of the maximum bending stress at  $P$  in Case I to that in Case II is \_\_\_\_\_ (rounded off to one decimal place).

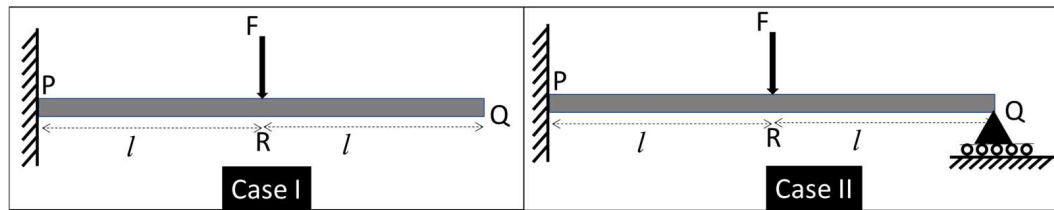

Q.58

A simply supported Aluminium column of length 1 m and rectangular cross-section  $w \times t$  with  $t \leq w$ , is subjected to axial compressive loading.

Young's modulus is 70 GPa. Yield stress under uniaxial compression is 120 MPa.

The value of  $t$  at which the failure load for yielding and buckling coincide is \_\_\_\_\_ mm.

**GATE 2022 Aerospace Engineering (AE)**

Q.59

A 0.5 m long *thin-walled* circular shaft of radius 2 cm is to be designed for an axial load of 7.4 kN and a torque of 148 Nm applied at its tip, as shown in the figure.

The allowable stress under uniaxial tension is 100 MPa.

Using maximum principal stress criterion, the minimum thickness,  $t$ , of the shaft so that it does not fail is \_\_\_\_\_ mm (rounded off to the nearest integer).

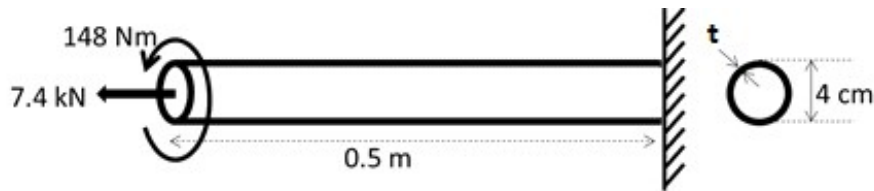

Q.60

A 10 kN axial load is applied eccentrically on a rod of square cross-section (1 cm  $\times$  1 cm) as shown in the figure.

The strains measured by the two strain gages attached to the top and bottom surfaces at a distance of 0.5 m from the tip are  $\epsilon_1 = 0.0016$  and  $\epsilon_2 = 0.0004$ , respectively.

The eccentricity in loading,  $e$  is \_\_\_\_\_ mm.

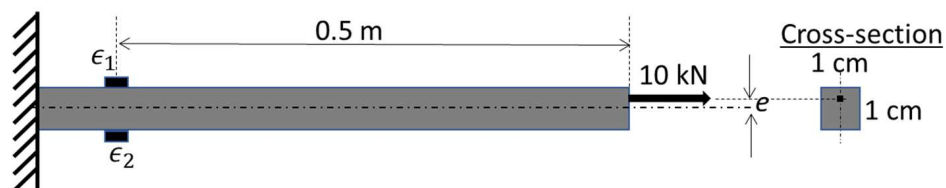

**GATE 2022 Aerospace Engineering (AE)**

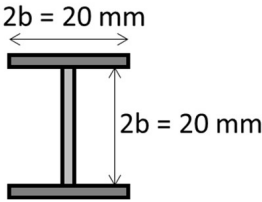
<p>Q.61</p>	<p>For a <i>thin-walled</i> I section, the width of the two flanges as well as the web height are the same, i.e., <math>2b = 20</math> mm. Thickness is 0.6 mm.</p> <p>The second moment of area about a horizontal axis passing through the centroid is _____ <math>\text{mm}^4</math>.</p> <div style="text-align: center;">  </div>

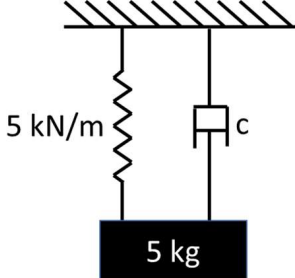
<p>Q.62</p>	<p>A damper with damping coefficient, <math>c</math>, is attached to a mass of 5 kg and spring of stiffness 5 kN/m as shown in figure. The system undergoes under-damped oscillations.</p> <p>If the ratio of the 3<sup>rd</sup> amplitude to the 4<sup>th</sup> amplitude of oscillations is 1.5, the value of <math>c</math> is _____ Ns/m (rounded off to the nearest integer).</p> <div style="text-align: center;">  </div>



**GATE 2022 Aerospace Engineering (AE)**

Q.63

A uniform rigid prismatic bar of total mass  $m$  is suspended from a ceiling by two identical springs as shown in figure.

Let  $\omega_1$  and  $\omega_2$  be the natural frequencies of mode I and mode II respectively ( $\omega_1 < \omega_2$ ).

The value of  $\omega_2/\omega_1$  is \_\_\_\_\_ (rounded off to one decimal place).

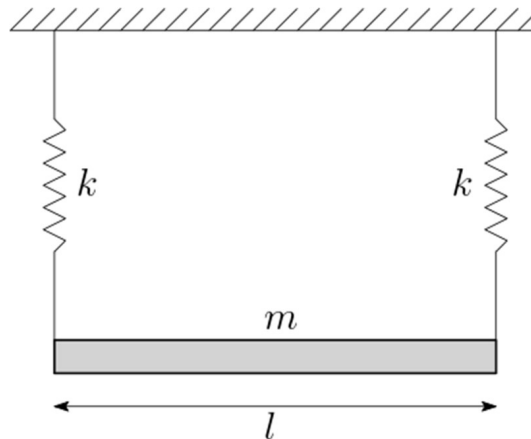

Q.64

An ideal ramjet is to operate with exhaust gases optimally expanded to ambient pressure at an altitude where temperature is 220 K. The exhaust speed at the nozzle exit is 1200 m/s at a temperature of 1100 K.

Given:  $\gamma = 1.4$  at 220 K;  $R = 287 \text{ J/(kg-K)}$  for air

$\gamma = 1.33$  at 1100 K;  $R = 287 \text{ J/(kg-K)}$  for exhaust gases.

The cruise speed of this ramjet is \_\_\_\_\_ m/s (rounded off to nearest integer).

**GATE 2022 Aerospace Engineering (AE)**

Q.65

A multistage axial compressor takes in air at 1 atm, 300 K and compresses it to a minimum of 5 atm.

The mean blade speed is 245 m/s and work coefficient,  $\frac{\Delta C_\theta}{U}$  is 0.55 for each stage. For air, use  $C_p = 1005 \text{ J/(kg-K)}$ ,  $R = 287 \text{ J/(kg-K)}$  and  $\gamma = 1.4$ .

If the compression is isentropic, the number of stages required is \_\_\_\_\_ (rounded off to the next higher integer).



Q. No.	Session	Question Type	Subject Name	Key/Range	Mark
1	8	MCQ	GA	B	1
2	8	MCQ	GA	C	1
3	8	MCQ	GA	C	1
4	8	MCQ	GA	A	1
5	8	MCQ	GA	B OR C	1
6	8	MCQ	GA	C	2
7	8	MCQ	GA	C	2
8	8	MCQ	GA	A	2
9	8	MCQ	GA	A	2
10	8	MCQ	GA	B	2
11	8	MCQ	AE	C	1
12	8	MCQ	AE	D	1
13	8	MCQ	AE	B	1
14	8	MCQ	AE	C	1
15	8	MCQ	AE	C	1
16	8	MCQ	AE	B	1
17	8	MCQ	AE	B	1
18	8	MCQ	AE	D	1
19	8	MCQ	AE	A	1
20	8	MCQ	AE	B	1
21	8	MCQ	AE	B	1
22	8	MCQ	AE	A	1
23	8	MCQ	AE	B	1
24	8	MSQ	AE	B, C	1
25	8	MSQ	AE	B, D	1
26	8	MSQ	AE	B, C	1
27	8	MSQ	AE	A, D	1
28	8	MSQ	AE	B, C	1
29	8	MSQ	AE	A, C, D	1
30	8	MSQ	AE	B, C, D	1
31	8	NAT	AE	8.6 to 9.1	1
32	8	NAT	AE	5.55 to 5.80	1
33	8	NAT	AE	109 to 111	1
34	8	NAT	AE	5.7 to 6.0	1
35	8	NAT	AE	51.5 to 52.6	1
36	8	MCQ	AE	C	2
37	8	MCQ	AE	C	2
38	8	MCQ	AE	C	2
39	8	MCQ	AE	B	2
40	8	MCQ	AE	B	2
41	8	MCQ	AE	C	2
42	8	MCQ	AE	B	2
43	8	MSQ	AE	A, B	2
44	8	MSQ	AE	A, C	2



45	8	MSQ	AE	A	2
46	8	MSQ	AE	B, C, D	2
47	8	MSQ	AE	B, D	2
48	8	NAT	AE	7.4 to 7.7	2
49	8	NAT	AE	2 to 2	2
50	8	NAT	AE	88 to 91	2
51	8	NAT	AE	9500 to 9800	2
52	8	NAT	AE	1.24 to 1.28	2
53	8	NAT	AE	0.14 to 0.15	2
54	8	NAT	AE	-0.057 to -0.053	2
55	8	NAT	AE	49 to 51 OR -51 to -49	2
56	8	NAT	AE	44 to 46	2
57	8	NAT	AE	2.6 to 2.7	2
58	8	NAT	AE	43 to 48	2
59	8	NAT	AE	1 to 1	2
60	8	NAT	AE	0.95 to 1.05	2
61	8	NAT	AE	2700 to 2960	2
62	8	NAT	AE	19 to 21	2
63	8	NAT	AE	1.7 to 1.8	2
64	8	NAT	AE	545 to 555	2
65	8	NAT	AE	6 or greater than 6	2